

IPI BY BISON
 603 L STREET
 LINCOLN, NE 68508
 TOLL FREE: 1-800-637-7968
 FAX: 1-800-638-0698
 www.ipibybison.com

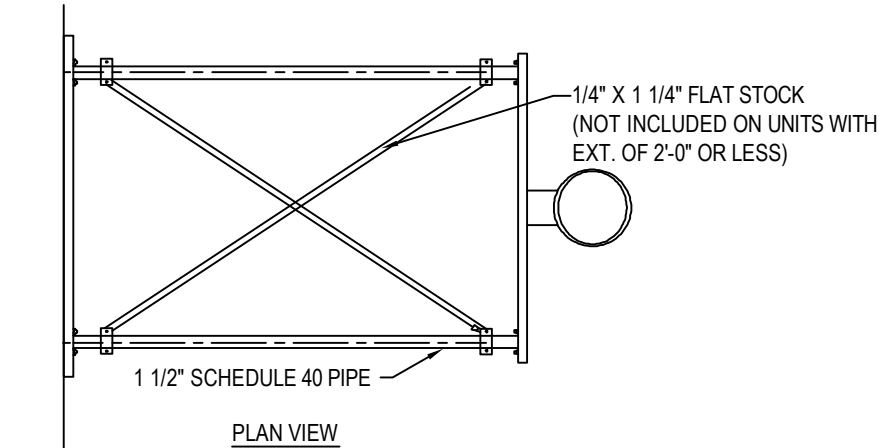

PLAN VIEW

CONSULT FACTORY FOR SPECIAL
 EXTENSIONS BEYOND 10'-0"

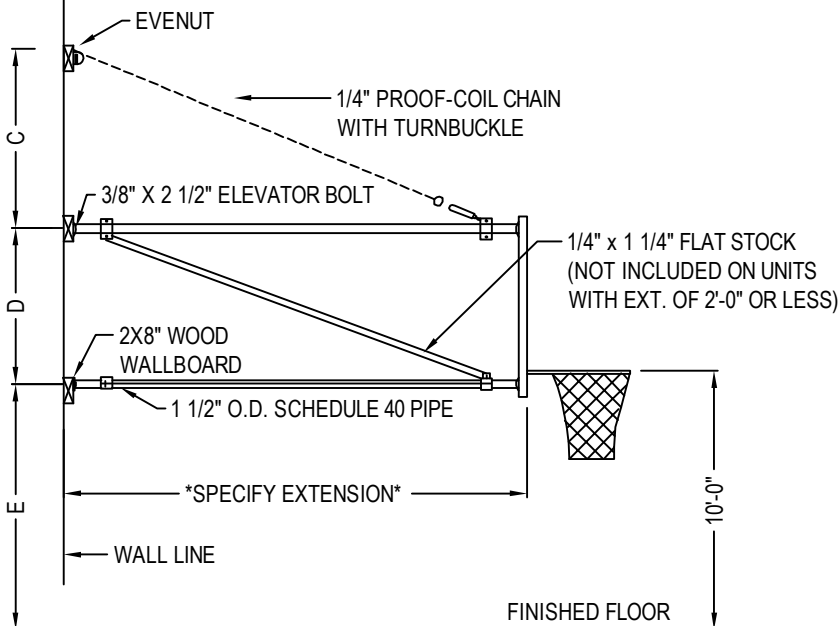

SIDE ELEVATION

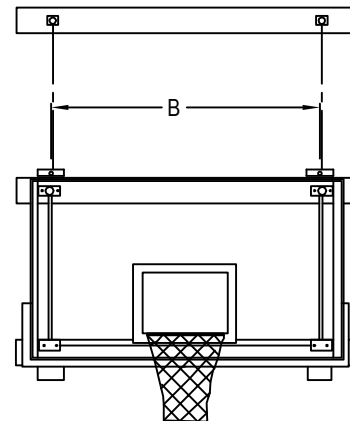

SPECIFY BACKBOARD REQUIRED
 (BA42XL SHOWN WITH DURASKIN PADDING)

FRONT ELEVATION

NOTES:

1. INSTALLATION TO BE COMPLETED IN ACCORDANCE WITH MANUFACTURER'S SPECIFICATIONS.
2. DO NOT SCALE DRAWING.
3. THIS DRAWING IS INTENDED FOR USE BY ARCHITECTS, ENGINEERS, CONTRACTORS, CONSULTANTS AND DESIGN PROFESSIONALS FOR PLANNING PURPOSES ONLY. THIS DRAWING MAY NOT BE USED FOR CONSTRUCTION.
4. ALL INFORMATION CONTAINED HEREIN WAS CURRENT AT THE TIME OF DEVELOPMENT BUT MUST BE REVIEWED AND APPROVED BY THE PRODUCT MANUFACTURER TO BE CONSIDERED ACCURATE.
5. CONTRACTOR'S NOTE: FOR PRODUCT AND COMPANY INFORMATION VISIT www.CADdetails.com/info AND ENTER REFERENCE NUMBER 4846-001.

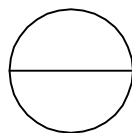

WALL MOUNTED BACKSTOPS

IP10WB: STATIONARY