

CONSULT FACTORY FOR SPECIAL EXTENSIONS BEYOND 10'-0"

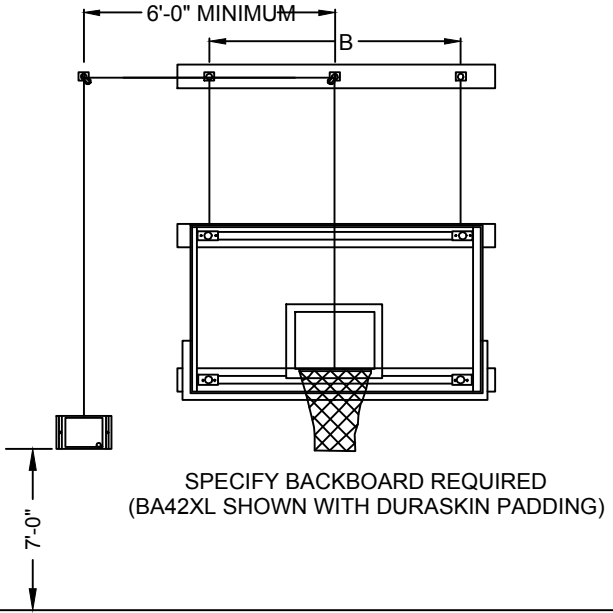
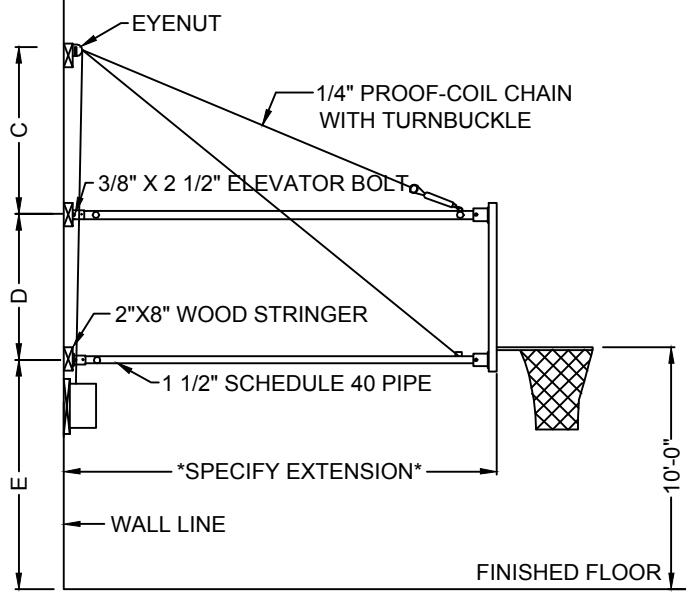

SIDE ELEVATION

FRONT ELEVATION

- NOTES:**
1. INSTALLATION TO BE COMPLETED IN ACCORDANCE WITH MANUFACTURER'S SPECIFICATIONS.
 2. DO NOT SCALE DRAWING.



PRODUCT SPECIFICATION

IP12WF: FOLD UP

REVISED 8/1/17